



**KENTEC
DISPLAY**

FOR APPROVAL

WE ARE PLEASED IN SENDDING YOU HEREWITH OUR SPECIFICATION AND DRAWING FOR YOUR APPROVAL. PLEASE RETURN TO US ONE COPY OF “FOR APOVAL” WITH YOUR APPROVED SIGNATURES.

YOUR MODULE NO.: _____ OUR MODULE NO.: K50DWN2-V1-FF

YOUR SPEC NO.: _____ OUR FULL SPEC NO.: FS- K50DWN2-V1-FF -01

APPROVED BY		

APPROVED BY CUSTOMER



K50DWN2-V1-FF

Product

Standard LCD Module
800 x RGB x 480 Dots
5" 16.7M colors TFT display
Wide temperature
With white LED backlight
With touch screen



CONTENTS

	<u>Page No.</u>
1. DOCUMENT REVISION HISTORY	3
2. GENERAL DESCRIPTION	4
3. MECHANICAL SPECIFICATIONS	5-6
4. INTERFACE SIGNALS	7
5. ABSOLUTE MAXIMUM RATINGS	8
6. ELECTRICAL SPECIFICATIONS	8
7. OPTICAL CHARACTERISTICS	9
8. TIMING CHARACTERISTICS	10
9. RELIABILITY TEST ITEM	11
10. SUGGESTIONS FOR USING LCD MODULES	12



1. Document revision history :

DOCUMENT REVISION	DATE	DESCRIPTION	PREPARED BY	APPROVED BY
01	2011.03.28	Preliminary verions.	MF Zou	



2. General Description

- 5.0”(diagonal), 800 x RGB x 480 dots, 16.7M colors, Normal white TN, TFT LCD module.
- Viewing Direction: 6 o’clock.
- Controller: SSD1963 graphic controller/driver.
- 8080 system 8-bit or 16-bits
- With internal voltage booster.
- Logic voltage: 3.3V (typ.).
- With 4-wire resistive touch screen

3. Mechanical Specifications

The mechanical detail is shown in Fig. 1 and summarized in Table 1 below.

Table 1

Parameter		Specifications	Unit
Outline dimensions		118.5(W) x 77.55(H) x 7.9(D) (Exclude FPC, cables of backlight)	mm
Color TFT 800xRGBx480	TP aiew area	--	mm
	TP view area	--	mm
	LCD active area	108.0(W) x 64.8(H)	mm
	Display format	800 x RGB x 480	dots
	Color configuration	RGB Side-stripes	-
	Dot size	0.135 (W) x 0.135(RGB)	mm
Weight		TBD	grams

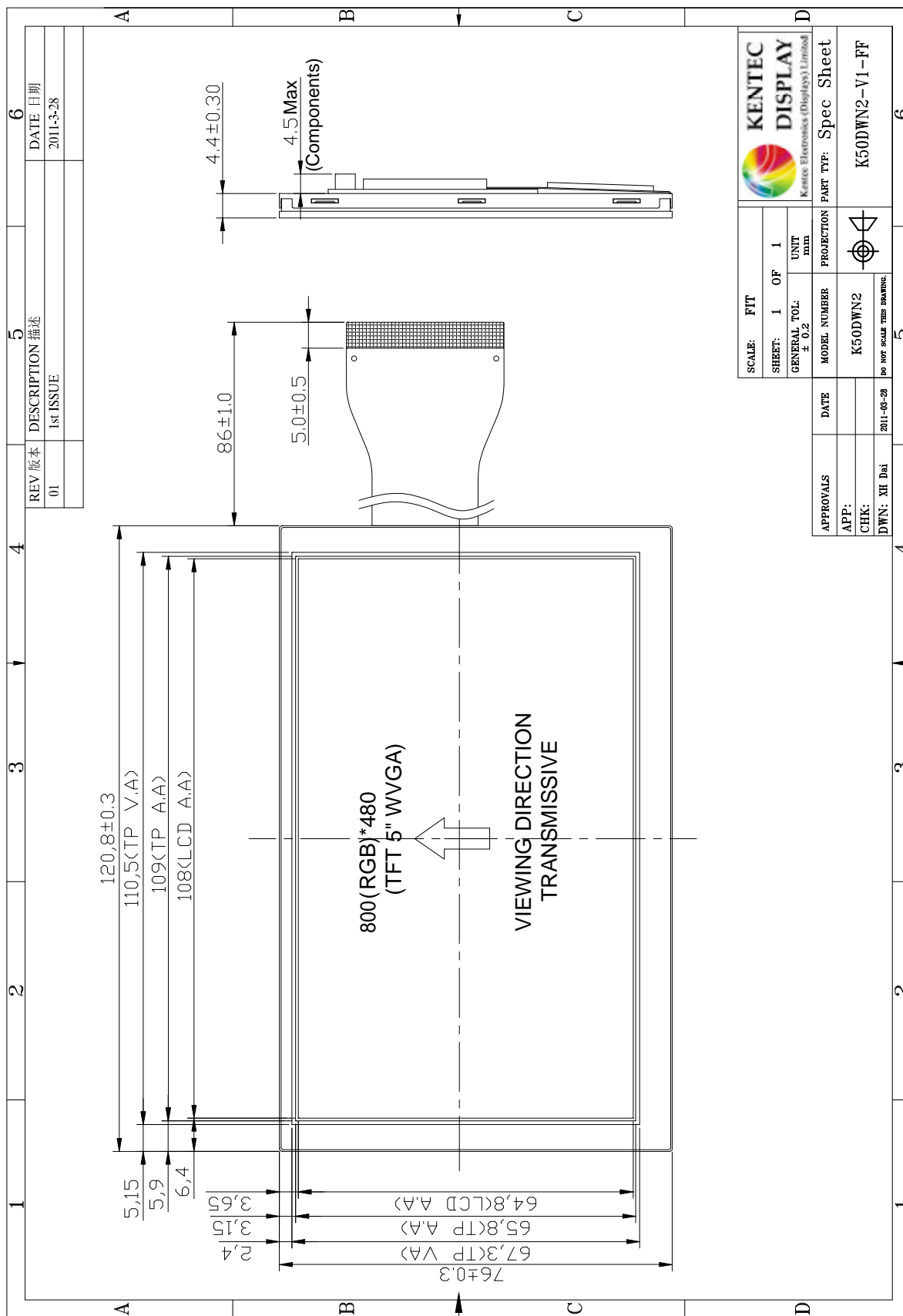

Figure 1: Outline Drawing 1

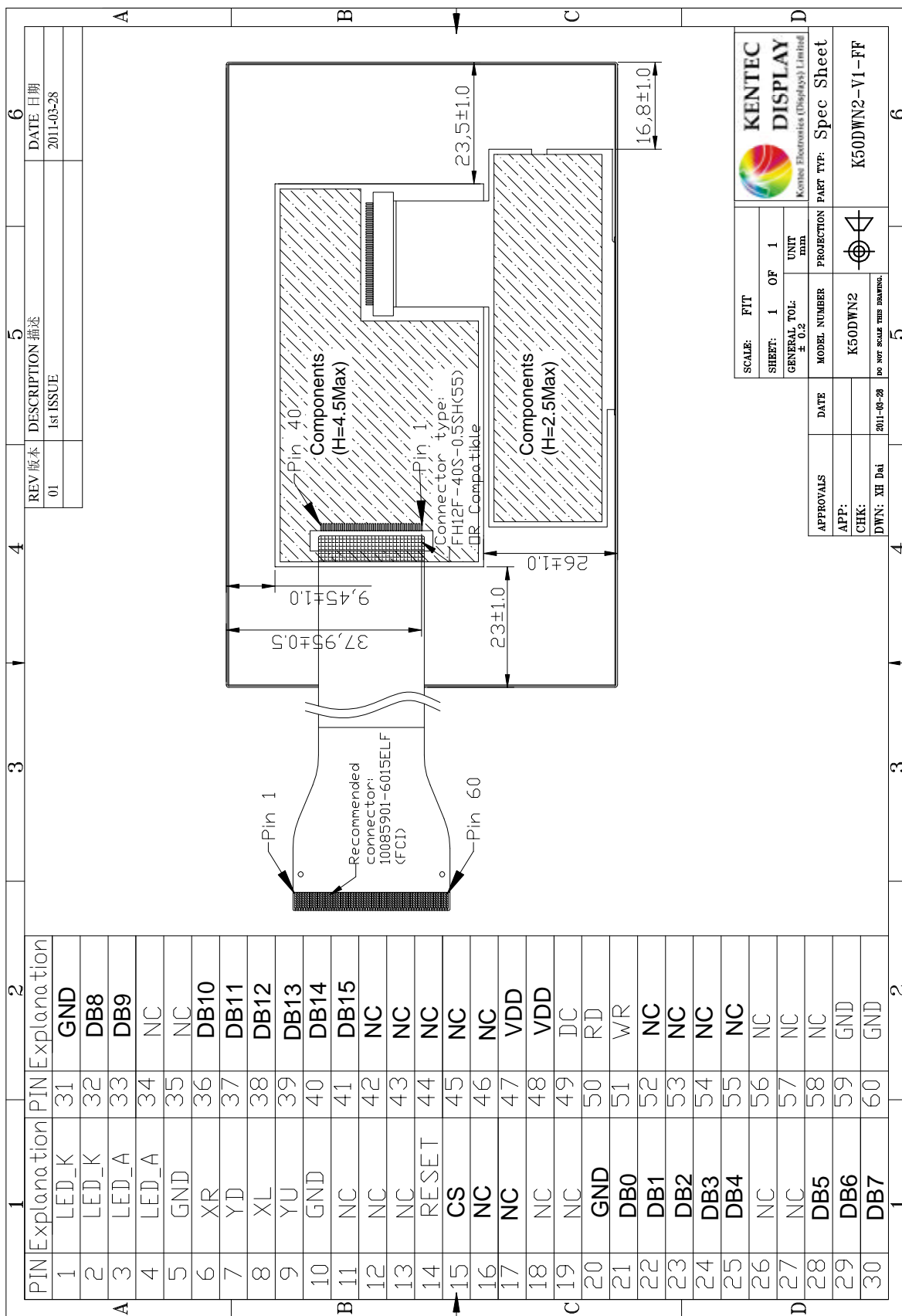

Figure 2: Outline Drawing 2

SCALE: FIT		KENTEC DISPLAY Kentec Electronics (Displays) Limited	
SHEET: 1	OF 1	UNIT: mm	PROJECTION: 1st Angle
GENERAL TOL: ± 0.2		MODEL NUMBER: K50DWN2	PART TYP: Spec Sheet
APPROVALS:	DATE:	APP: [Signature]	CHK: [Signature]
DWN: XH Dal	2011-03-28	PART NO: K50DWN2-V1-FF	
DO NOT SCALE THIS DRAWING.		5	



4. Interface signals

Table 2: Pin assignment

Pin No.	Symbol	Description
1-2	LED_K	Power supply for LED backlight
3-4	LED_A	
5	GND	Power supply (system ground)
6	XR	Terminal of touch panel.
7	YD	
8	XL	
9	YU	
10	GND	Power supply (system ground)
11-13	NC	No connection
14	RESET	System reset pin
15	CS	Chip select input
16-19	NC	No connection
20	GND	Un-used data pin, connect to GND
21-25	DB[0-4]	Bi-directional data bus(DB0-DB4)
26-27	NC	No connection
28-30	DB[5-7]	Bi-directional data bus(DB5-DB7)
31	GND	Un-used data pin, connect to GND
32-33	DB[8-9]	Bi-directional data bus(DB8-DB9)
34-35	NC	No connection
36-41	DB[10-15]	Bi-directional data bus(DB10-DB15)
42-46	NC	No connection
47-48	VDD	Supply voltage for logic
49	DC	Parallel Interface
50	RD	I80 system: Serves as a read signal and reads data at the low level.
51	WR	I80 system: Serves as a write signal and writes data at the rising edge.
52-58	NC	No connection
59-60	GND	Power supply (system ground)

Note: LCD interface circuit example ().



5. Absolute Maximum Ratings

5.1 Electrical Maximum Ratings – for IC Only

Table 3: Electrical Maximum Ratings – for IC

Parameter	Symbol	Min.	Max.	Unit	Note
Supply voltage	VCC	-0.3	5.0	V	1
LED forward current	If	--	30	mA	
LED reverse	Vr	--	5.0	V	

Note:

- 1.VCC, GND must be maintained.
- 2.The modules may be destroyed if they are used beyond the absolute maximum ratings.

5.2 Environmental Condition

Table 4

Item	Operating temperature (Topr)		Storage temperature (Tstg) (Note 1)		Remark
	Min.	Max.	Min.	Max.	
Ambient temperature	-20°C	+70°C	-30°C	+80°C	Dry
Humidity (Note 1)	80% max. RH for Ta ≤ 40°C < 50% RH for 40°C < Ta ≤ Maximum operating temperature				No condensation

Note 1: Product cannot sustain at extreme storage conditions for long time.

6. Electrical Specifications

Typical Electrical Characteristics

At Ta = 25 °C, VCC=IOVCC= 3.3V, GND=0V.

Table 5

Parameter	Symbol	Conditions	Min.	Typ.	Max.	Unit
Supply voltage (logic)	VDD-GND		3	3.3	3.6	V
Input signal voltage	VIH		0.8VDD	-	VDD	V
	VIL		0	-	0.2VDD	V
Supply current (Logic & LCD)	IDD	VDD=3.3V	-	15	19	mA
Supply current (1) (LED)	ILED		-	36	40	mA

Note (1): LED backlight required current constant power supply. LED circuit was in 2 chain parallel and with 6 LEDs serial per chain.

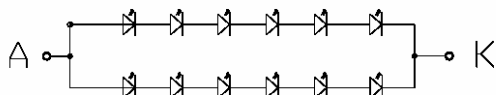



7. Optical Characteristics

Table 6: Optical specifications

Items	Symbol	Condition	Specifications			Unit	Note
			Min.	Typ.	Max.		
Luminance	L _w		200	250	-	cd/m ²	
Contrast Ratio	CR		480	600	-	-	
Response Time	T _R +T _F		-	10	20	ms	
Chromaticity	White	X _w	(0.292)	(0.307)	(0.322)	-	
		Y _w	(0.333)	(0.348)	(0.363)	-	
Viewing angle	Hor.	φ1 + φ2	Center CR=10	130	150	-	deg.
	Ver.	θ1 + θ2		110	130	-	

Note 1: Definition of Contrast Ratio (CR):

The contrast ratio can be calculated by the following expression.

$$\text{Contrast Ratio (CR)} = L_{63} / L_0$$

L₆₃: Luminance of gray level 63

L₀: Luminance of gray level 0

$$\text{CR} = \text{CR} (10)$$

CR (X) is corresponding to the Contrast Ratio of the point X at Figure in Note 5.

Note 2: Definition of Response Time (TR, TF):

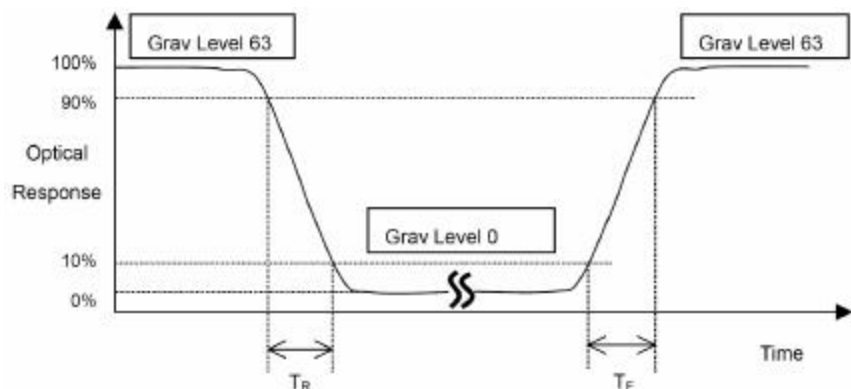

Figure 3

Note 3: Viewing Angle

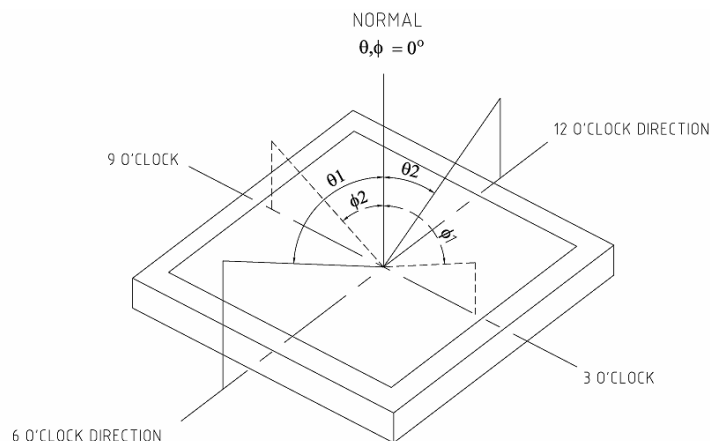

Figure 4



The above “Viewing Angle” is the measuring position with Largest Contrast Ratio; not for good image quality. View Direction for good image quality is 6 O’clock. Module maker can increase the “Viewing Angle” by applying Wide View Film.

Note 4: Measurement Set-Up:

The LCD module should be stabilized at a given temperature for 20 minutes to avoid abrupt temperature change during measuring. In order to stabilize the luminance, the measurement should be executed after lighting Backlight for 20 minutes in a windless room.

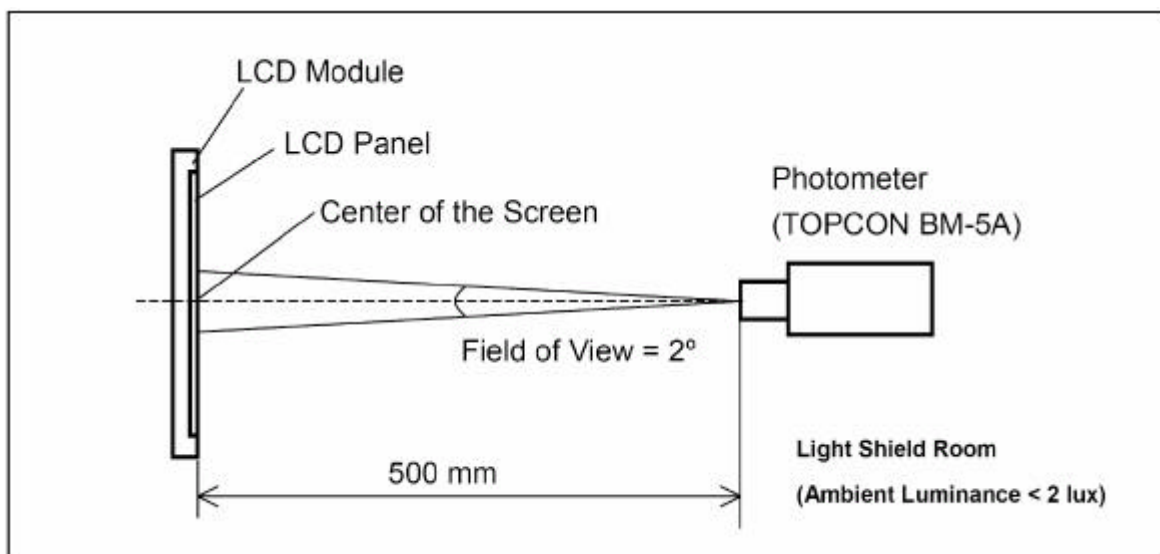

Figure 5

8. AC Characteristics and Signal timing

Please refer SSD1963 datasheet.

8.1 Driver code example for TI IDM-SBC ().

8.2 Driver code example for TI DK-LM3S9B96 ().



9. Reliability Test Item

	Test Item	Test Condition	Remark
1	High temperature storage	70 ; 240H	
2	Low temperature storage	-20 ; 240H	
3	High temperature High humidity	50 , 80%RH; 240H	Operation
4	High temperature operation	60 ; 240H	
5	Low temperature operation	-10 ; 240H	
6	Temperature Shock	-20 ? 60 ; 100cycle, 1Hrs/cycle	Non-operation
7	Electrostatic Discharge	Contact ±4kV, Class B Air ±8kV, Class B	
8	Image sticking	25 , 4H	
9	Vibration	Frequency range : 10~55Hz Stoke : 1.5mm Sweep : 10~55~10Hz 2 Hours for each direction of X,Y,Z (total 6 Hours)	Non-operation JIS C7021, A-10 Conduction A : 15 minutes
10	Mechanical shock	100G, 6ms, ±X, ±Y, ±Z, 3 times for each direction	Non-operation JIS C7021, A-10 Conduction C
11	Vibration (with carton)	Random vibration : 0.015G ² /Hz from 2~200Hz -6dB/Octave from 200~500Hz	ICE 68-34
12	Drop (with carton)	Height : 60cm 1 corner, 3 edges, 6 surfaces	
13	Pressure	5 kg, 5 sec	

10. Suggestions for using LCD modules

10.1 Handling of LCM

10.1.1. The LCD screen is made of glass. Don't give excessive external shock, or drop from a high place.

10.1.2. If the LCD screen is damaged and the liquid crystal leaks out, do not lick and swallow. When the liquid is attach to your hand, skin, cloth etc, wash it off by using soap and water thoroughly and immediately.



10.1.3. Don't apply excessive force on the surface of the LCM.

10.1.4. If the surface is contaminated ,clean it with soft cloth. If the LCM is severely contaminated , use Isopropyl alcohol/Ethyl alcohol to clean. Other solvents may damage the polarizer . The following solvents is especially prohibited: water , ketone Aromatic solvents etc.

10.1.5. Exercise care to minimize corrosion of the electrode. Corrosion of the electrodes is accelerated by water droplets, moisture condensation or a current flow in a high-humidity environment.

10.1.6. Install the LCD Module by using the mounting holes. When mounting the LCD module make sure it is free of twisting, warping and distortion. In particular, do not forcibly pull or bend the I/O cable or the backlight cable.

10.1.7. Don't disassemble the LCM.

10.1.8. To prevent destruction of the elements by static electricity, be careful to maintain an optimum work environment.

- Be sure to ground the body when handling the LCD modules.
- Tools required for assembling, such as soldering irons, must be properly grounded.
- To reduce the amount of static electricity generated, do not conduct assembling and other work under dry conditions.
- The LCD module is coated with a film to protect the display surface. Exercise care when peeling off this protective film since static electricity may be generated.

10.1.9. Do not alter, modify or change the the shape of the tab on the metal frame.

10.1.10. Do not make extra holes on the printed circuit board, modify its shape or change the positions of components to be attached.

10.1.11. Do not damage or modify the pattern writing on the printed circuit board.

10.1.12. Absolutely do not modify the zebra rubber strip (conductive rubber) or heat seal connector

10.1.13. Except for soldering the interface, do not make any alterations or modifications with a soldering iron.

10.1.14. Do not drop, bend or twist LCM.



10.2 Cautions for installing and assembly if the module with Touch Panel

10.2.1. Use a buffer material (Gasket) between the touch panel and Front-case to protect damage and wrong operating. The dimension of the buffer material's edge between the TP V.A. edge is Min. 0.3mm.

10.2.2. We recommend to design a case that it can't over the boundary of the active area Max. 0.5mm in order to prevent an operation at outside of the active area which can't guarantee the specified durability, because operation at the outside of the active area cause serious damage of a transparent.

10.2.3. When design case for installing Module, you would consider give a distance about $0.2 \pm 0.15\text{mm}$ between the module edge to case inside.

10.2.4. The corners of the product are not chamfered. When positioning and fixing the product on the case, we suggest that you would provide a R part on the conner of the case so as not to apply load on the corner of the transparent module.

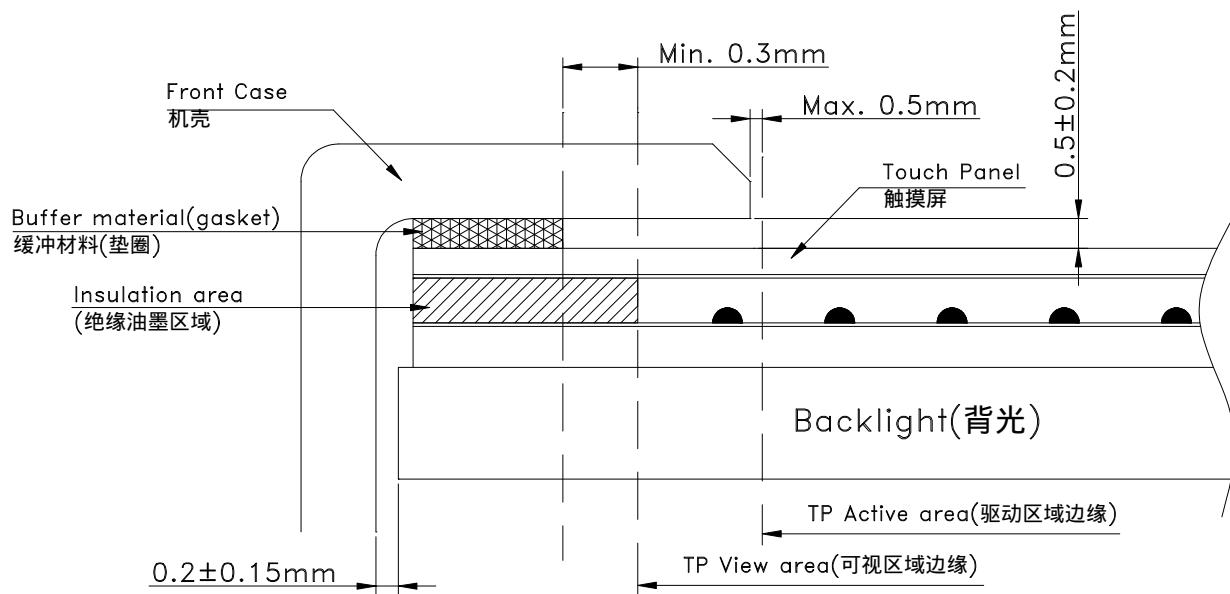

10.3 Storage

10.3.1. Store in an ambient temperature of 5 to 45 °C, and in a relative humidity of 40% to 60%. Don't expose to sunlight or fluorescent light.

10.3.2. Storage in a clean environment, free from dust, active gas, and solvent.

10.3.3. Store in antistatic container.

- END -